

The Class and Home Problems section is intended to present novel and innovative scenarios that can enhance the teaching of chemical engineering topics. Submissions must have clear learning objectives, outcomes, or similar statements. The fit within a typical chemical engineering (or closely related) curriculum should be clear. Problems may represent a new application of fundamental principles, substantive adaptations that enable effective pedagogical approaches, or new non-proprietary applications of software. Manuscripts should follow the same general guidelines as other *CEE* submissions, but should be submitted directly to Dr. David Silverstein (david.silverstein@uky.edu).

# THE LAMBERT W FUNCTION IN ULTRAFILTRATION AND DIAFILTRATION

GREG FOLEY

*Dublin City University • Dublin 9, Ireland*

In chemical engineering we tend to encounter two kinds of mathematical problems—first, problems for which analytical solutions are available and second, problems for which numerical solutions are required. When we say that an analytical solution is available we generally mean that the solution can be expressed explicitly in terms of elementary functions. These are functions that can be written as combinations of powers, exponentials, logs, trigonometric functions, etc. However, there are many functions, denoted special functions, that are not elementary but arise sufficiently frequently that they have been assigned names. They often occur as solutions to differential equations or as integrals of elementary functions. Some have a series definition while others are defined as inverse functions and their computation is not necessarily straightforward. The special functions with which chemical engineers are most familiar are probably the Bessel functions and these occur in many transport problems that occur in cylindrical geometry. While special functions are often unfamiliar, many of them are routinely available as built-in functions in the more advanced computational packages like Matlab,<sup>®</sup> Mathematica,<sup>®</sup> and its online version

WolframAlpha, and Maple.<sup>®</sup> Some special functions can be computed from their series definition, if they have one, using simple spreadsheet software.<sup>[1]</sup> In a sense, therefore, there is nothing particularly “special” about them, at least from an engineering computation perspective.



**Greg Foley** is a chemical engineer with B.E. and Ph.D. degrees from University College Dublin and an M.S. degree from Cornell University. He has been a lecturer in Bioprocess Engineering in the School of Biotechnology, Dublin City University, since 1986. He is currently the associate dean for Teaching and Learning in the Faculty of Science and Health. He has published extensively in the chemical engineering literature, mainly in the area of membrane science and engineering, and in 2013 he authored the textbook, *Membrane Filtration: A Problem Solving Approach* with MATLAB, published by Cambridge University Press. As well as focusing on membrane technologies, much of his current research is aimed at developing novel computational methods for general chemical engineering analysis and design.

© Copyright ChE Division of ASEE 2016

The study of membrane separation processes is generally considered a core element of chemical engineering education. Membrane separation processes are used in areas as diverse as desalination (reverse osmosis), ultrafiltration (dairy processing), microfiltration (downstream processing), and hemodialysis (medicine). The membranes business is a multi-billion dollar one.

Ultrafiltration is a crossflow membrane separation technique used mainly for the concentration of polymer solutions in continuous, batch, and fed-batch modes. Although ultrafiltration is not complex from a conceptual point of view (being essentially a “sieving” process), ultrafiltration calculations are never straightforward. This is a direct consequence of the fact that the flowrate through the membrane tends to be a function of the logarithm of the solute concentration. Indeed, previous work has described how this logarithmic dependence leads to the emergence of two functions, the Logarithmic Integral and the Exponential Integral, in the design of batch, fed-batch, and single-pass ultrafiltration systems.<sup>[1]</sup>

In diafiltration, diluent (water or buffer) is added to a polymer solution that also undergoes batch ultrafiltration, either simultaneously or prior to the diafiltration step. The most common type of industrial diafiltration is constant volume diafiltration, which is described in the section on Constant Volume Diafiltration, below. The effect of diafiltration, regardless of the precise way it is performed, is to flush low molecular weight impurities out of the solution while retaining high molecular weight products in the feed tank. In that sense, diafiltration is somewhat similar to dialysis, although there are key differences between these processes in terms of the driving forces involved.

The purpose of this paper is to show how two problems, one in ultrafiltration and one in constant volume diafiltration, can be solved readily using a special function called the Lambert W function. This is a function that has recently been shown to arise in the calculation of the breakeven radius of insulation, a classic problem in heat transfer.<sup>[2]</sup> In addition to the theory, numerical examples are provided in each case.

## THE LAMBERT W FUNCTION

Consider the non-linear algebraic equation

$$xe^x - a = 0 \quad (1)$$

Then

$$x = W(a) \quad (2)$$

where  $W$  represents the Lambert W function, also known as the Omega Function or the Product Logarithm. The Lambert W function is available as an in-built function in all of the computational packages mentioned above. They all employ the syntax  $\text{LambertW}(x)$ , while Mathematica and Wolfram-

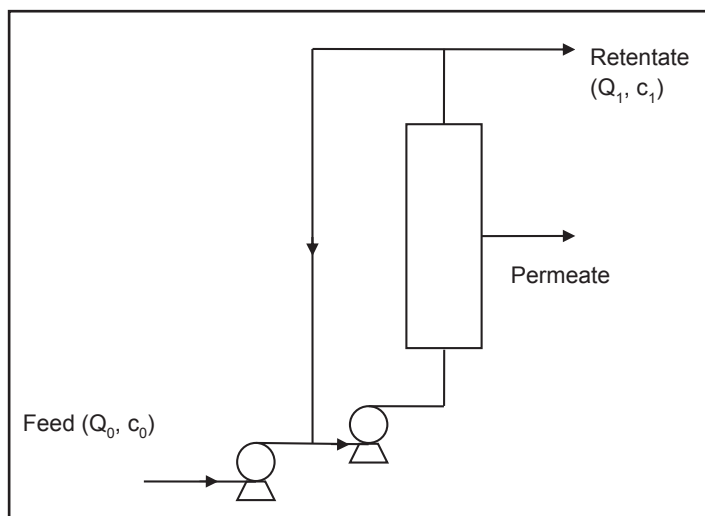

Figure 1. Process layout for continuous feed-and-bleed ultrafiltration.

Alpha also accept  $\text{ProductLog}(x)$ . WolframAlpha will even accept  $W(x)$ . In this paper we show how the Lambert W function arises in two problems in membrane engineering: (i) calculating the exit concentration in continuous feed-and-bleed ultrafiltration and (ii) calculating a certain water requirement in constant volume diafiltration.

## CONTINUOUS FEED-AND-BLEED ULTRAFILTRATION

Continuous feed-and-bleed ultrafiltration is a process for concentrating macromolecular solutions and is characterized by partial recycle of the retentate, as described in Figure 1.<sup>[1]</sup>

The recycle increases the mass transfer coefficient in the module, thus increasing the permeate flux [see Eq. (3)]. Feed-and-bleed systems are generally assumed to be well-mixed and consequently the concentration at any point in the module is assumed to be equal to the exit concentration.

Consider a volumetric flowrate,  $Q_0$ , of a macromolecular solution with concentration,  $c_0$ , entering a feed-and-bleed ultrafiltration system as shown in Figure 1. The exit concentration from the system is  $c_1$ .

The membrane has area,  $A$ , and the flux,  $J$ , is assumed to be given by the *limiting flux model* as

$$J = k \ln \frac{c_{\text{lim}}}{c_1} \quad (3)$$

where  $c_{\text{lim}}$  is the limiting concentration (more typically known as the “gel” concentration),  $k$  is the mass transfer coefficient, and it is assumed that no solute passes through the membrane.<sup>[3,4]</sup> Eq. (3) is derived by considering the balance between convective flow of solute towards the membrane and mass transfer of

solute away from the membrane. The limiting concentration is essentially a property of the solution and represents the high-pressure limit of the wall concentration, *i.e.*, the solute concentration at the membrane surface.

Overall and solute balances are easily shown (a useful student exercise) to lead to the following non-linear algebraic equation for the exit concentration:

$$\frac{Q_0}{kA}(1-x) - \ln x - \ln \frac{c_{lim}}{c_0} = 0 \quad (4)$$

where

$$x = \frac{c_0}{c_1} \quad (5)$$

Eq. (4) is conveniently written as

$$D(1-x) - \ln x - \ln B = 0 \quad (6)$$

where

$$D = \frac{Q_0}{kA} \quad (7)$$

and

$$B = \frac{c_{lim}}{c_0} \quad (8)$$

Rearranging Eq. (6) gives

$$Dx + \ln x = D - \ln B \quad (9)$$

Therefore

$$\ln(xe^{Dx}) = \ln\left(\frac{e^D}{B}\right) \quad (10)$$

It is easy to show then that

$$Dxe^{Dx} - \frac{D}{B}e^D = 0 \quad (11)$$

Referring back to Eqs. (1) and (2), the following solution can be deduced.

$$x = \frac{1}{D} W\left(\frac{D}{B}e^D\right) \quad (12)$$

The process of getting from Eq. (6) to Eq. (11) can be demonstrated to the student or, if the instructor prefers, it can be posed as challenge in creative algebra. It should be noted as well that the leap from Eq. (6) to Eq. (11) can be done directly with the computer algebra capability of WolframAlpha.<sup>[5]</sup> This is something that the student could explore. The one “difficulty” that does arise, however, is that WolframAlpha often reports solutions that are very general and correct in a mathematical sense (often involving complex numbers) and the generality of these solutions might be confusing to engineering students who are mainly concerned with solutions that are physically meaningful.

## *... ultrafiltration calculations are never straightforward.*

### Numerical Example 1

#### Problem statement

A 10 l/min flowrate of a protein solution enters an ultrafiltration module operating in feed-and-bleed mode. The mass transfer coefficient is  $6 \times 10^{-6}$  m/s, the membrane area is 3.0 m<sup>2</sup>, and the limiting concentration ( $c_{lim}$ ) is 250 g/L while the feed concentration ( $c_0$ ) is 20 g/L.

Calculate the exit concentration.

#### Solution

Using the parameter values supplied and making sure to use SI units, we get

$$D = \frac{10 \times 10^{-3} / 60}{6 \times 10^{-6} \times 3} = 9.259 \quad (12a)$$

$$B = \frac{250}{20} = 12.5 \quad (12b)$$

Now we simply enter the following code into WolframAlpha<sup>[5]</sup>:

```
=1/9.259*ProductLog(9.259/12.5*exp(9.259))
```

The value returned is

$$x = 0.757$$

Thus

$$c_1 = \frac{c_0}{x} = \frac{20}{0.757} = 26.42 \text{ g/L} \quad (12c)$$

Thus a problem that in times past might have been solved by a trial and error method, or perhaps by manual implementation of the Newton-Raphson algorithm, can now be solved with a simple statement in WolframAlpha.

It is worth mentioning that feed-and-bleed systems are often operated as a number of equal-area modules in series, *i.e.*, the retentate from one stage forms the feed to the next. In this context, a nice student exercise would be to show

$$D(x_{i-1} - x_i) - \ln x_i - \ln B = 0 \quad (13)$$

where

$$x_i = \frac{c_i}{c_0} \quad (14)$$

with

$$x_0 = 1 \quad (15)$$

The student could then be required to show that

$$x_i = \frac{1}{D} W\left(\frac{D}{B}e^{Dx_{i-1}}\right) \quad (16)$$

## CONSTANT VOLUME DIAFILTRATION

Consider a solution with solute concentration,  $c_0$ . It is desired to reduce the concentration of this solute. To that end, the solution is subjected to constant volume diafiltration (CVD). Diluent (*e.g.*, water) is added at a rate that exactly balances the permeate flowrate as illustrated in Figure 2.

Now for a given amount of diluent added,  $V_w$ , and a constant retentate volume,  $V_0$ , the solute concentration,  $c_f$ , in the retentate at the end of the diafiltration is given by the well-known expression<sup>[3]</sup>

$$\frac{c_f}{c_0} = e^{-V_w/V_0} \quad (17)$$

where  $c_0$  is the initial concentration and the solute is assumed to have a rejection coefficient of zero, *i.e.*, the solute passes unimpeded through the membrane.

A solute balance over the entire process can be written

$$V_0 c_0 = V_0 c_0 e^{-V_w/V_0} + c_p V_w \quad (18)$$

where  $c_p$  is solute concentration in the permeate collection vessel at the end of the diafiltration.

Now defining

$$x = \frac{V_w}{V_0} \quad (19)$$

and

$$b = \frac{c_p}{c_0} \quad (20)$$

Eq. (18) becomes

$$1 - e^{-x} - bx = 0 \quad (21)$$

Now suppose we want to calculate the amount of water required to produce *permeate* with a *given concentration*. One might need to do this to satisfy a stream specification for a process occurring further downstream. Multiplying across by  $e^x$  and rearranging we get

$$e^x (bx - 1) + 1 = 0 \quad (22)$$

Now multiplying across by  $e^{-1/b}$  we get

$$(x - 1/b)e^{(x-1/b)} + \frac{1}{b}e^{-1/b} = 0 \quad (23)$$

Referring to Eqs. (1) and (2), we get

$$x = \frac{1}{b} + W\left(-\frac{1}{b}e^{-1/b}\right) \quad (24)$$

Again, the process of getting from Eq. (21) to Eq. (23) can be left, if desired, as an exercise for the student. Eq. (21) can also be solved directly with WolframAlpha.

## Numerical Example 2

### Problem Statement

A solute is to be recovered from a known volume of liquid using constant volume diafiltration. If the concentration of solute in the permeate at the end of the process is to be half that of the original feed concentration, calculate how much diluent is required relative to the initial solution volume.

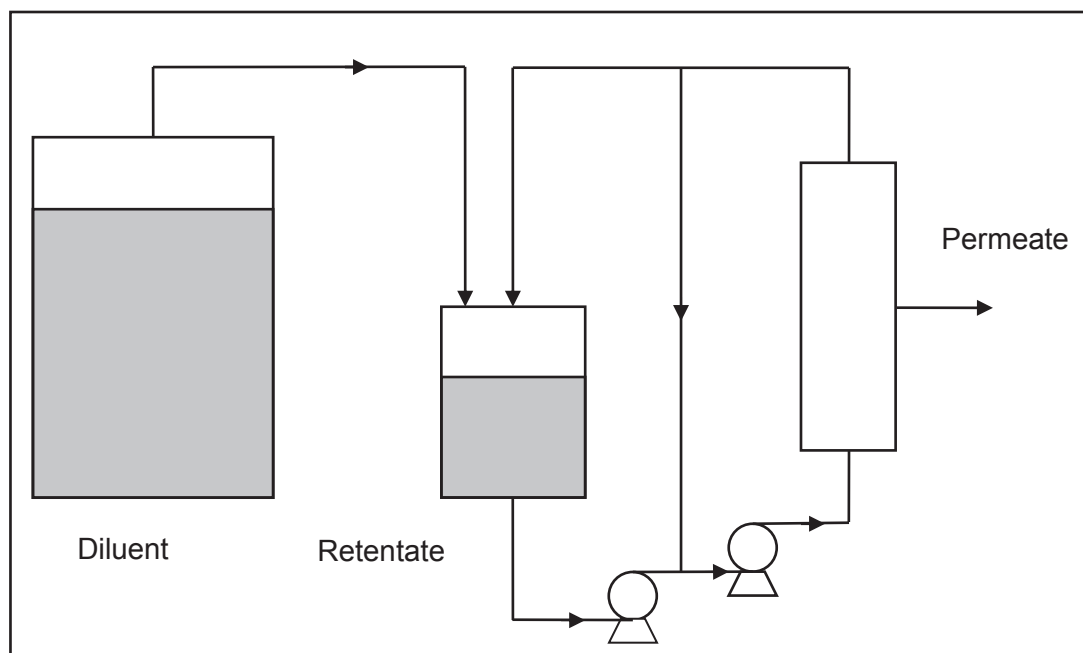

**Figure 2.** Process configuration for constant volume diafiltration.

### Solution

In this case,  $b = 0.5$ , and thus the answer is obtained by direct application of Eq. (24). Using WolframAlpha we simply write=

$$1/0.5+\text{ProductLog}(-1/0.5*\exp(-1/0.5))$$

WolframAlpha returns the value

$$x = \frac{V_w}{V} = 1.594 \quad (24a)$$

As a quick additional calculation, the student could be asked to compute  $c_r$ , *i.e.*, the relative solute concentration in the retentate at the end of the process.

### CONCLUSIONS

This paper has outlined the use of the Lambert W function to solve two problems that arise in the analysis of ultrafiltration and diafiltration problems. Of course, the key equations, Eqs. (6) and (21) can also be solved using conventional numerical methods and the exercises described here are easily extended to include a comparison between the Lambert W approach and the conventional numerical approach.

As mentioned in previous work,<sup>[2]</sup> the use of readily available computational tools like WolframAlpha is changing the nature of chemical engineering calculations. Trial and error

solutions are largely obsolete as are many of the elegant and ingenious graphical techniques that still adorn many of the classic chemical engineering textbooks. Only in some instances (perhaps) do they retain some pedagogical utility. Furthermore, if the engineer is willing to embrace relatively unfamiliar special functions, calculations that were once done with iterative methods can now, in some circumstances at least, be computed explicitly, thus making repeated calculations much easier to perform. On a more philosophical note, it is noteworthy that “solving the problems,” a standard feature of chemical engineering education, can increasingly be an opportunity to learn new mathematics as well as to practice the “doing” of chemical engineering.

### REFERENCES

1. Foley, G., “Three Classic Ultrafiltration Problems Solved With the Exponential Integral,” *Ed. For Chem. Engineers*, **6**, e90-e96 (2011)
2. Foley, G., “The Break-Even Radius of Insulation Computed Using Excel Solver and WolframAlpha,” *Chem. Eng. Ed.*, **48**(3), 185 (2014)
3. Cheryan, M., *Ultrafiltration and Microfiltration Handbook*, CRC Press, Boca Raton, FL (1999)
4. Blatt, W.F., A. Dravid, A.S. Michaels, and L. Nielsen, “Solute Polarization and Cake Formation in Membrane Ultrafiltration: Causes, Consequences and Control Techniques,” In: *Membrane Science and Technology*, J.E. Flinn (Ed.), Plenum Press, NY (1970)
5. Available online at <<http://www.wolframalpha.com>> [accessed June 2015] □